

# ROAD WEIGHER

ARW-1 / ARW-900

FOR VEHICLE WEIGHING



## ARW-1 [ INDICATOR ]

## ARW-900 [ PLATE ]

- **High resolution TFT LCD**
- **Simple operation**
- **Compact size & lightweight**
- **Watertight case**
- **USB host control**

- **Thin thickness**
- **Best durability IP67**
- **Selectable weigh-in-motion**
- **Push-pull connector**
- **Wheels for easy transport**

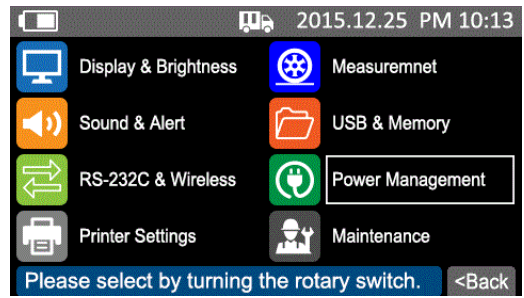
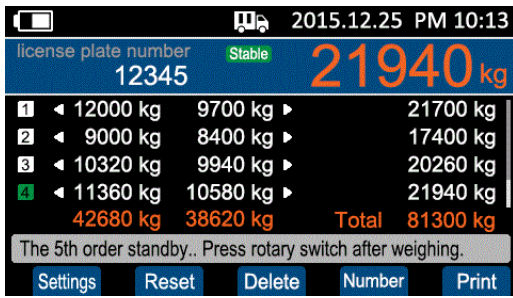

• **User friendly 4.3inch full color TFT LCD**



- **Store data by USB stick**
- **Easily firmware upgrade**

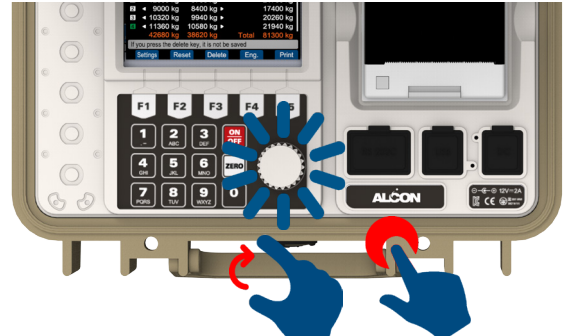

- **Anyone can easily operate with ROTARY SWITCH.**



- **Transmitting data to the PC**
- **1 input & 3 output for control**



- **IP67 push-pull connector & rubber cap holder**



- **Light weight for handy**

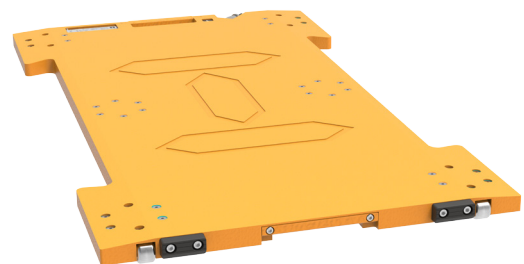

- **Wheels for easy transport**
- **Nonslip rubber for an upright position.**

# ARW-1 (INDICATOR)

## DIMENSIONS

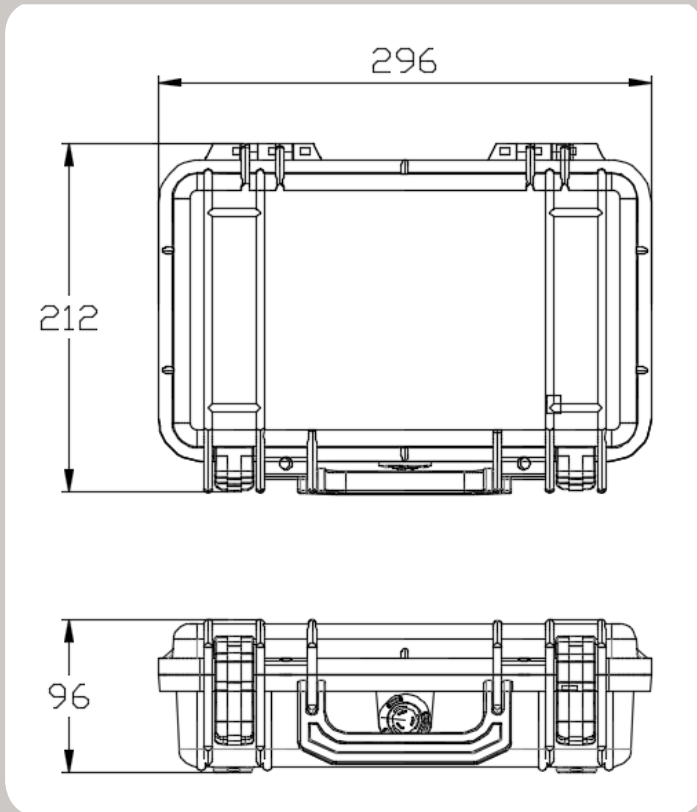

## SPECIFICATIONS

MODEL	ARW-1
DISPLAY	Full color 4.3inch TFT
MEMORY	500,000,000 axles
CASE	Watertight case
SCALE CONNECTION	Up to 6 scales (plates)
PRINTER	Direct line thermal printer (paper: 40 x 57mm)
INTERFACE	RS232C and external control (1 input & 3 output)
USB PORT	For memory stick & firmware upgrade
BATTERY	Rechargeable Li-ion pack + PCM
CHARGER	SMPS 12VDC, 2A
OPERATING TIME	Approx. 80hr
OPERATING TEMPERATURE	-20°C ~ 60°C
OPERATING HUMIDITY	85% R.H. (no condensation)
PRODUCT WEIGHT	2.7kg
OPTIONAL	Tablet PC (for handy control)

# ARW-900 (PLATE)

## DIMENSIONS

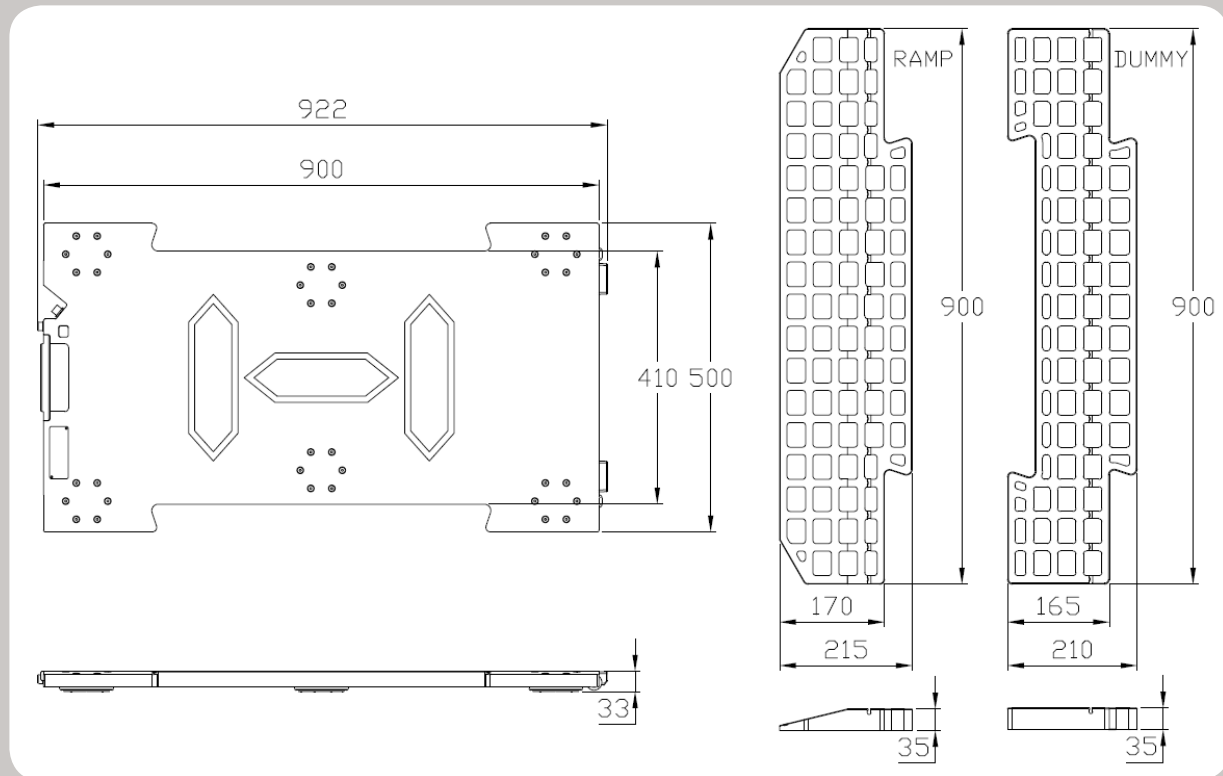

## SPECIFICATIONS

MODEL	ARW-900-10	ARW-900-15	ARW-900-20
CAPACITY	10,000kg	15,000kg	20,000kg
DIVISION	10kg	10kg	20kg
PLATFORM SIZE	900 x 500 x 33		900 x 600 x 33
WEIGH IN MOTION	Selectable (under 10km/h speed)		
RAMP & DUMMY MATERIAL	Urethane		
IP GRADE	IP67		
OPERATING TEMPERATURE	-20°C ~ 60°C		
OPERATING HUMIDITY	85% R.H. (no condensation)		
PRODUCT WEIGHT	Approx. 22kg		Approx. 33kg

**SAFETY • CONVENIENCE • QUALITY • PERFORMANCE • STABILITY**