

WIRELESS ROAD WEIGHER

ARW-1F / ARW-900F

FOR VEHICLE WEIGHING



ARW-1F [INDICATOR]

ARW-900F [PLATE]

- High resolution TFT LCD
- Simple operation
- Compact size & lightweight
- Watertight case
- USB host control

- Thin thickness
- Best durability IP66
- Standard Li-ion battery
- Up to 600hrs of battery life
- Selectable weigh-in-motion

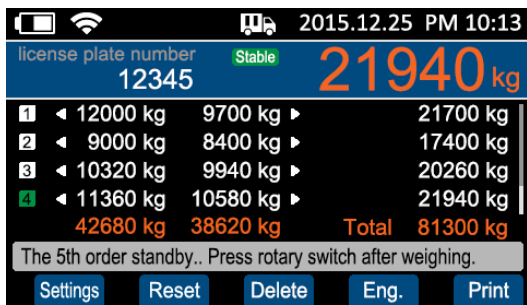

User friendly 4.3inch full color TFT LCD

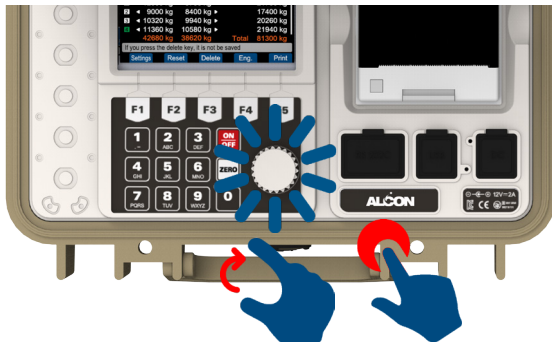
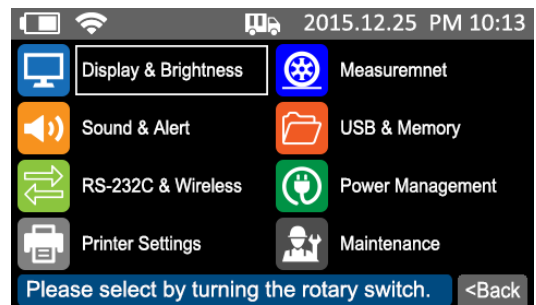

- Anyone can easily operate with **ROTARY SWITCH**.

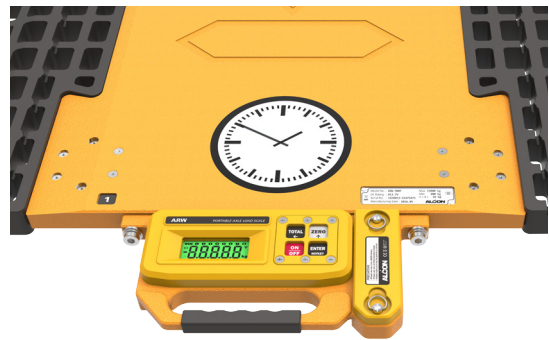

- **600hrs operating time**



- Store data by **USB stick**
- Easily firmware upgrade

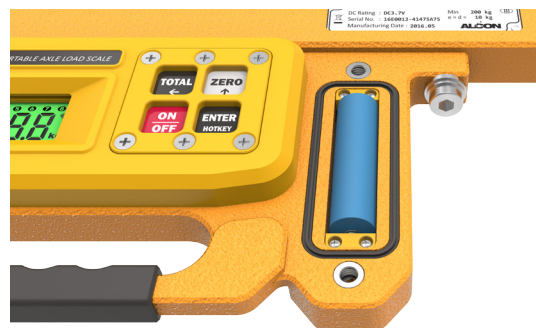

- Uses standard **18650 battery**



- Transmitting data to the **PC**
- 1input & 3output for control

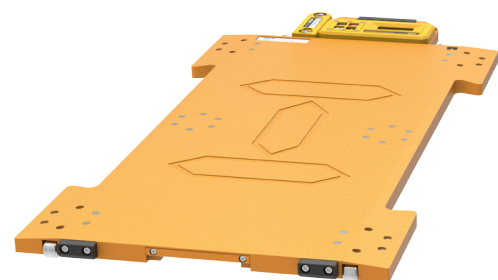

- **Wheels for easy transport**
- **Nonslip rubber for an upright position.**

ARW-1F (INDICATOR)

DIMENSIONS

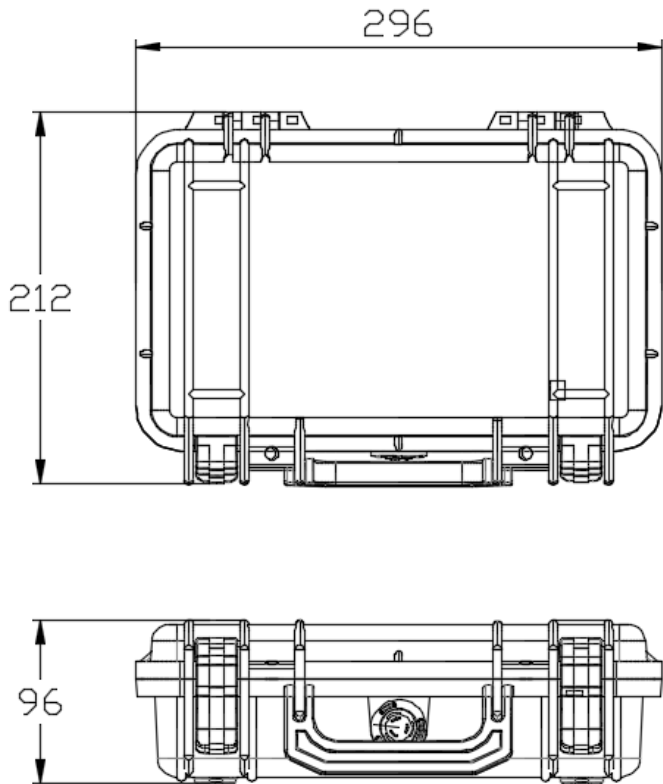

SPECIFICATIONS

MODEL	ARW-1F
DISPLAY	Full color 4.3inch TFT
MEMORY	500,000,000 axles
CASE	Watertight case
PRINTER	Direct line thermal printer (paper: 40 x 57mm)
INTERFACE	RS232C and external control (1 input & 3 output)
WIRELESS METHOD	Zigbee
USB PORT	For memory stick & firmware upgrade
BATTERY	Rechargeable Li-ion pack + PCM
CHARGER	SMPS 12VDC, 2A
OPERATING TIME	Approx. 80hr
OPERATING TEMPERATURE	-20°C ~ 60°C
OPERATING HUMIDITY	85% R.H. (no condensation)
PRODUCT WEIGHT	2.7kg
OPTIONAL	Tablet PC (for handy control)

ARW-900F (PLATE)

DIMENSIONS

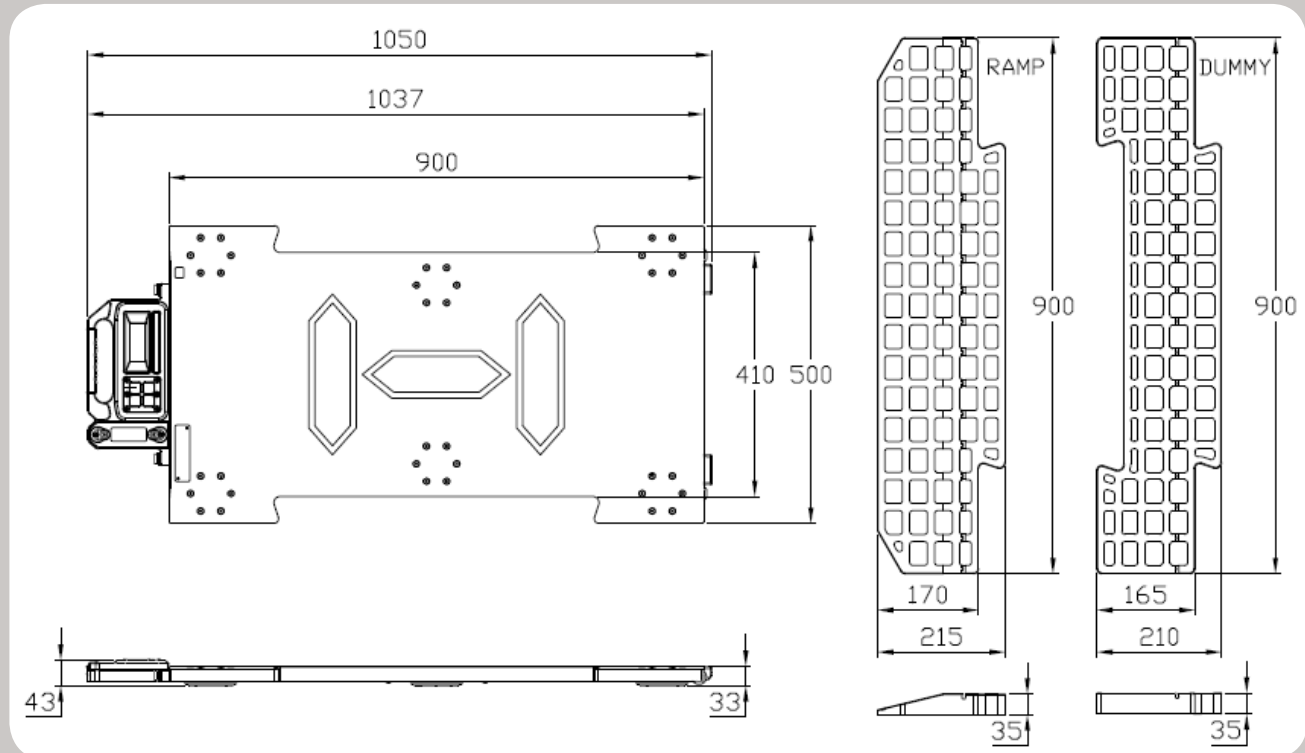

SPECIFICATIONS

MODEL	ARW-900F-10	ARW-900F-15	ARW-900F-20
DISPLAY	FSTN LCD 5digit & LED backlight		
CAPACITY	10,000kg	15,000kg	20,000kg
DIVISION	10kg	10kg	20kg
PLATFORM SIZE	900 x 500 x 33		900 x 600 x 33
WEIGH IN MOTION	Selectable (under 10km/h speed)		
RAMP & DUMMY MATERIAL	Urethane		
WIRELESS METHOD	Zigbee		
IP GRADE	IP66		
BATTERY	Rechargeable 18650 Li-ion + PCM		
CHARGER	Exclusive battery charger		
OPERATING TIME	Approx. 600hr		
OPERATING TEMPERATURE	-20°C ~ 60°C		
OPERATING HUMIDITY	85% R.H. (no condensation)		
PRODUCT WEIGHT	Approx. 26kg		Approx. 37kg