

ROAD WEIGHER

ARW-500

FOR VEHICLE WEIGHING

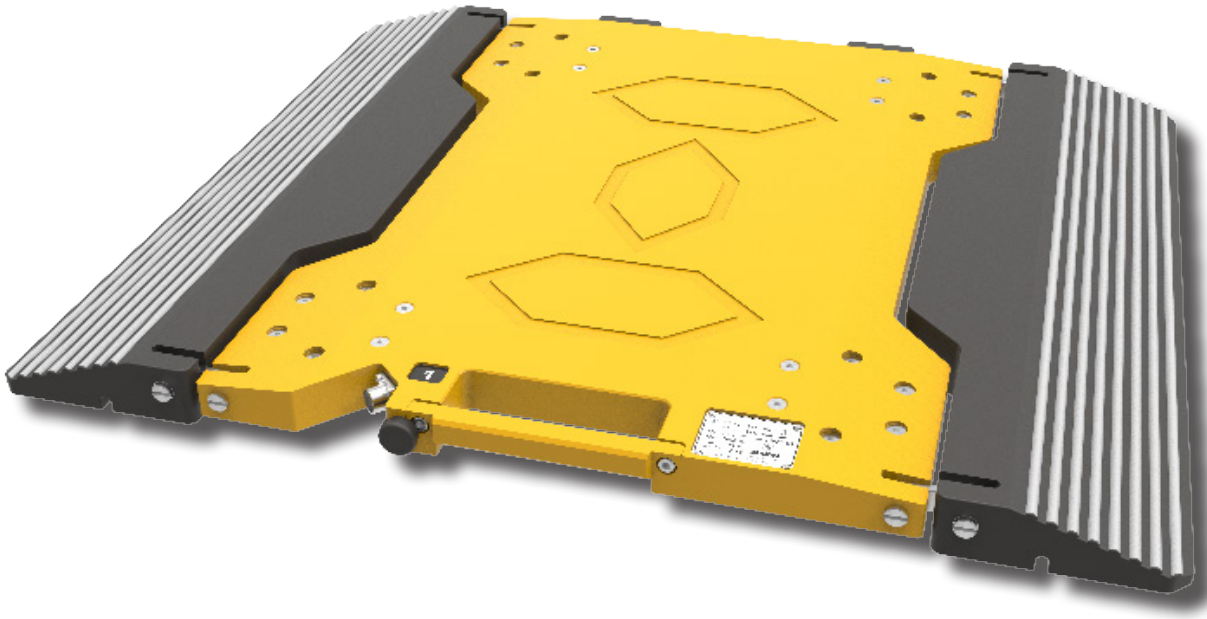

- Thin thickness
- Integral ramp pad
- Best durability IP67
- Push-pull connector

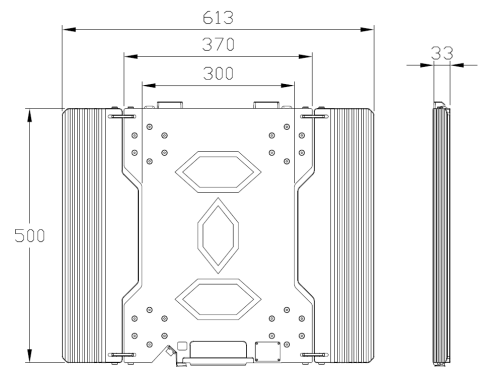
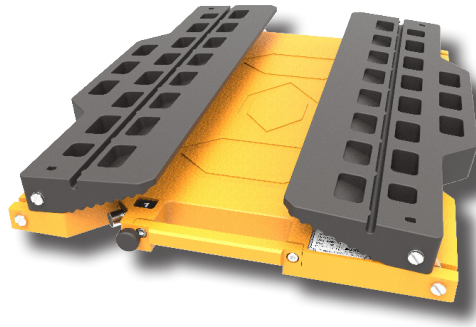

MODEL	ARW-500-01	ARW-500-02	ARW-500-05	ARW-500-15
CAPACITY	1,000kg	2,000kg	5,000kg	15,000kg
DIVISION	1kg	2kg		10kg
RAMP MATERIAL	Rubber			
IP GRADE	IP67			
OPERATING TEMP.	-20°C ~ 60°C			
OPERATING HUMIDITY	85% R.H. (no condensation)			
PRODUCT WEIGHT	14kg (included ramp)			